



10-YEAR LIMITED WARRANTY

Warranty & Care Instructions

THANK YOU FOR YOUR PURCHASE

Congratulations on your recent Positive Posture mattress purchase. We're confident that your new mattress will provide you with many years of great sleep.

Your new mattress includes a 10-Year Limited Warranty. If you have any questions or issues during or after the warranty period, please contact Positive Posture directly by calling 720-616-5000 or sending an email to service@positiveposture.com.

A good sleep regimen, combined with healthy eating habits, exercise, and regular massage is a great way to live a happy, productive life.

Thank you again for making Positive Posture a part of your daily life.

REGISTER YOUR WARRANTY NOW

Please register your product by visiting www.positiveposture.com/register. Registering your product will ensure that your warranty claim is handled quickly and easily.

WARRANTY INTRODUCTION

Please retain this Limited Warranty with your proof of purchase for ten (10) years from the date of your mattress purchase.

For ten (10) years from your date of purchase, your Positive Posture mattress or foundation, used with proper support, is protected by a limited manufacturer's warranty. We will repair or replace your product if a defect covered under this Limited Warranty is found. This Limited Warranty applies when the products are used as intended, following all Positive Posture instructions and requirements for care. The details of this warranty, and some limitations, are provided in the paragraphs below.

All claims under this Limited Warranty must be accompanied by the original purchase receipt indicating date of purchase, name of the retailer, delivery date of the mattress, and the details of original ownership. In the event the original purchaser is unable to present the proof of purchase, the manufacturer may decide, at its sole discretion, to offer Limited Warranty coverage based upon the production date of the mattress.

This Limited Warranty is valid only for the original purchaser of the product. An original purchaser is one who purchases the product directly from Positive Posture or an authorized retailer of Positive Posture. This Limited Warranty does not apply if purchaser or owner is not the original purchaser of this product.

COVERAGE

The Positive Posture mattress, mattress outer cover, and foundation are covered by this Limited Warranty against defects in materials and workmanship.

Mattress Coverage

Visible depression and/or sinking of the surface of more than one (1) inch that are not the result of use of an improper or unsupportive foundation or adjustable base. Values lower than one (1) inch are considered normal settlement of the structure under the weight of the human body. Instruction on measuring method can be found at page 7.

Mattress Outer Cover Coverage

Except for demo or floor model covers, Positive Posture mattress outer coverings are covered by this Limited Warranty against manufacturing defects in materials and workmanship for 2 years. Positive Posture may, at its sole discretion, repair or replace a defective mattress cover. In the event that Positive Posture replaces the mattress cover, Positive Posture will replace it with the current style of cover available for the mattress, which may be a different color or material than the original cover provided.

Flat Foundation Coverage

Flat Foundation Coverage: Except for demo or floor model, Positive Posture flat foundations are covered by this Limited Warranty against manufacturing defects in materials and workmanship for 2 years. Positive Posture foundations are designed to work with a bed frame capable of supporting the load of the foundation and mattress. Therefore, if Purchaser uses an inappropriate bed frame or mattress with this foundation, such use will void this limited warranty and all other warranties, whether expressed or implied, including, without limitation, the implied warranties of merchantability and fitness for a partial purpose. Positive Posture may, at its sole discretion, repair or replace a defective foundation. In the event that Positive Posture replaces the foundation, Positive Posture will replace it with the current style of cover available, which may be a different color or material than the original cover provided. Positive Posture reserves the right to invalidate this Limited Warranty if the frame is determined, in Positive Posture's reasonable discretion, to be inadequate or if the foundation is found to be in an unsanitary condition. This Limited Warranty covers the following items during normal wear: 1) Structural damage or broken components; 2) Squeaks or rattles; 3) Sagging that is not associated with use of an improper bed frame. This limited warranty does not cover: 1) structural damage from using an improper bed frame; 2) physical abuse or damage to the structure and/or cover material of the foundation, including but not limited to burns, cuts, tears, or liquid damage; 3) Replacement of another piece in the Positive Posture sleep system (e.g., mattress, pillows, etc.) unless other piece is also defective; 4) Product sold "as-is", "preconditioned", "reconditioned", "used", "comfort return", "returned", "previously owned", or any other similar wording indicating that the product is not "new" or of "first quality", or have previously been purchased or used by another customer.

TERMS

- The warranty coverage runs from the original date of purchase.
- This limited warranty is provided only to the original purchaser and is not transferable.
- For your warranty to be valid, your purchase must be directly from Positive Posture or an authorized Positive Posture dealer. No express or implied warranties are extended to persons who purchase the product from anyone other than Positive Posture or its authorized dealers, and all warranties to such persons, including the implied warranties of merchantability and fitness, are hereby excluded. The duration of any applicable implied warranties, included but not limited to the implied warranties of merchantability and fitness, shall not exceed the terms of this limited warranty. (Some states do not allow limitations on how long an implied warranty lasts, so this limitation may not apply to you.)

TERMS, CONTINUED...

- The Limited Warranty is valid only if the mattress has been used as follows. It has never been used in a way that causes harm, damage and/or deformation/alteration to the components of the product; In particular, the mattress is conceived solely for the repose of people. It is not indicated for children under 3 years of age and animals, nor for any other action than sleeping; in compliance with the recommended use and maintenance advice provided; the product has not been altered or tampered with by an unauthorized person; the mattress has not suffered intentional or accidental damage; the mattress has not been used in hotels, RVs, motor homes and the like. The above-mentioned actions relieve the manufacturer of any responsibility for any damage to people or things.
- Replacement of one piece due to manufacturing defect does not automatically result in the replacement of any other piece.
- Replacement of the mattress or foundation does not extend its limited warranty or begin a new limited warranty period. Positive Posture shall not be liable for incidental or consequential damages that result from the use of your Positive Posture product. (Some states do not allow the exclusion of limitation of incidental or consequential damages, so this exclusion may not apply to you.)

PROPER FOUNDATION/FRAME REQUIREMENTS

The use of a bed frame is important for the life and protection of your sleep system. Neither mattresses, individually, nor sleep systems (mattress and foundation combination) are intended to sit/lay flat on the floor, on a water bed frame, or on a platform of untreated wood or untreated wood covered with fabric.

Normal wear requires that a purchaser's mattress be continuously supported by a matching foundation or adjustable bed base with a proper bed frame sufficient to support the collective weight of the mattress, foundation, and user(s). A proper bed frame must:

- Be supporting, rigid & non-yielding.
- Provide sturdy support for both the mattress, foundation, and user(s) and include a center support and having at least 5-6 legs for Queen, King and California King, and 4 leg support for Twin and Full mattresses. In addition all frames must provide support for the head, foot and sides. See images to the right for visual examples.
- If used without a foundation the open spaces between slats must be no more than 2" (5 cm). If the surface has gaps of greater space, it is incumbent upon the purchaser to ensure that the frame utilized offers ample structural support by adding a solid platform on top of any open slatted mattress support system. Hardboard, plywood, particle board or a similar material, inserted between the mattress and the slatted platform, supporting the entire surface of the mattress will provide appropriate support.

Failure to have a proper bed frame or the use of an open slatted mattress support system in which the spaces between the slats are greater than 2" (5 cm), without the addition of a solid platform, will damage your mattress and may invalidate this limited warranty.

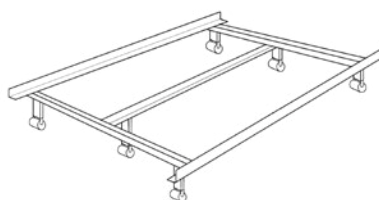
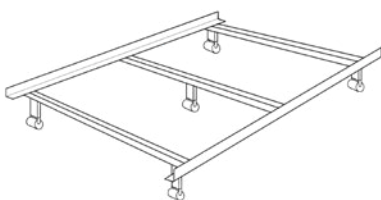

YOUR RESPONSIBILITIES, NOTES ABOUT USAGE, AND MOVING & CARE

- The materials used in a new mattress may have their own specific odor, which will diminish in a short period of time;
- If your mattress has a removable outer cover, use only a professional dry cleaning service to clean the outer cover. Do not remove or wash the inner cover;
- A slight depression or change in softness, due to morphological adaptation, shall be considered normal;
- The fabric cover must not get wet, or be washed with water or ironed;
- Do not spill liquids on the mattress or allow your mattress to get wet;
- Do not expose the mattress to direct sun; Do not use irons, blow dryers or other heat sources on the fabric cover or on the sheets when in place, and/or on the mattress itself;
- Do not use a heating pad or electric blanket;
- Do not use steamers or steam sterilizers to clean the mattress;
- Do not use solvents or chemical substances on the fabric;
- Do not apply any kind of cleaning or fabric protection applications on your mattress;
- Do not stand or jump on the mattress or the foundation;
- Avoid contact with sharp objects or edges that could tear or cut the mattress;
- Do not roll up or tie the mattress or leave it in a vertical position;
- Use with sheets and do not sleep directly on the mattress' cover;
- Air as often as possible, ideally every morning and, in particular, at any change of linens;
- Do not smoke, use candles, lighters, matches, or any other kind of open flame on or around your bed. Although your new Positive Posture mattress meets the requirements of the Federal Flammability Standard, 16 CFR 1633, when it is used alone or with the foundation(s) specified on the 16 CFR 1633 law tag attached to your mattress, it is not fireproof. In addition, sheets, blankets and other bedding can ignite and burn rapidly when exposed to open flames;
- If you need to move your mattress, carton or bag it and carry it on its side to avoid damage;
- Do not fold the product, doing so may cause damage;
- When handling or moving your mattress be careful of people, animals or things around you;
- When handling or moving your mattress, DO NOT leave it unattended in vertical position;
- Discard the plastic wrapping on your mattress as soon as possible; a child or pet can become entangled and suffocate;
- Never remove the white law label. This serves as a means of identification to establish your Limited Warranty rights. Without the legal tag label the Limited Warranty is void;
- Use approved foundations only;
- The general instructions of this Limited Warranty apply to the foundation, as well, in particular with respect to the instruction that no standing or jumping on the mattress is advised;
- To optimize the benefits of your mattress, you should use it in the designated head-to-foot direction with the label positioned upright, and at your feet. If you feel the need to rotate the bed to refresh its comfort, you can swivel the mattress by 180°, but do not flip the bed over so the logo is in an upside down position (see right).

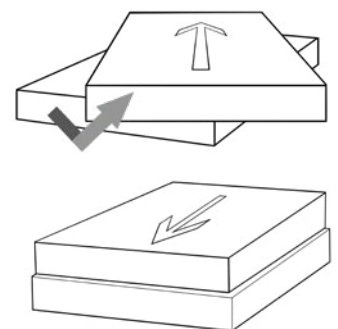

EXCLUSIONS FROM COVERAGE UNDER THIS LIMITED WARRANTY

- A normal increase in softness or recovery time of the materials which does not affect the pressure-relieving qualities of the mattress;
- Consumer firmness, temperature or comfort preference;
- Consumer bed height/weight or sheet fit preferences;
- Normal body impression(s) as defined as 1" or less;
- Damage associated with an improper bed frame, foundation, or adjustable base. See above description and illustrations for what constitutes a proper bed frame;
- Deterioration due to normal wear and tear and deterioration caused by external agents such as fire, water, steam, sunlight or electric blankets; Damage to any part of the structure and/or cover material, including but not limited to, burns, cuts, tears, liquid damage, pets, high humidity, body fluids, blood, vermin, and stains of any kind;
- Damage directly or indirectly caused by people, animals or things, due to the non-compliance with the instructions of Positive Posture on the recommended use and maintenance of the mattress;
- Floor models or demonstration samples sold at a discount (See separate warranty for demos and floor models);
- Product sold "as-is," "preconditioned," "reconditioned," "used," "comfort return," "returned", "previously owned", or any other similar wording indicating that the product is not "new" or of "first quality," or has previously been purchased or used by another consumer;
- Product sold by resellers who are not authorized Positive Posture mattress retailers;
- Replacement of the accompanying piece in the Positive Posture sleep system where only one piece is defective, unless that accompanying piece is also defective;
- The product as a remedy for any specific medical condition;
- Positive Posture does not warrant against any complications resulting from the use or inability to use this product;
- Claims made outside the 50 United States, District of Columbia, Puerto Rico, or U.S. Virgin Islands;
- Transportation, inspection, or removal costs of product, except in California.

DEMONSTRATION SAMPLES AND FLOOR MODEL COVERAGE

Demonstration samples ("demo(s)") and floor model(s) will enjoy a 10 year limited warranty from the date of manufacture as shown on the law tag located at the head of the bed. However, except for verifiable warranty defects, demos and floor models are sold "as is" and "with all faults" and covers on demos and floor models (whether removable or not) are not warranted or guaranteed. During this Limited Warranty, demo or floor model products purchased at a discount will be repaired by Positive Posture at no charge to the purchaser or will be replaced for a charge equal to the cost of the replacement product less the amount paid by the original purchase for the demo or floor model. If the demo or floor model product has been discontinued then the replacement charge will be the cost of the reasonable equivalent of the discontinued item (or any upgraded item) less the amount paid by the original purchaser for the demo or floor model product.

FILING A CLAIM

Before filing a claim, please have the following information ready:

- Your name, address, email address, and telephone number
- Copy of original receipt or proof of purchase (with your name on it)
- Product/Model
- Purchase date
- Manufacturing Date (located on the mattress law tag at the head of the bed)
- Bed Frame and Foundation Type (i.e. metal, wooden side rail, adjustable or platform)
- Malfunction condition (give as much detail as possible)

Once you have collected this information, please visit www.positiveposture.com/support and follow the instructions for filing a warranty claim on the page. Alternatively, you can call Positive Posture at 720-616-5000 to start the claim process.

Please note, the Positive Posture may send a mattress evaluation expert to assess the damage claim.

PRODUCT REPLACEMENT TERMS

If your Positive Posture mattress or foundation fails due to a manufacturing defect, the exclusive remedy under this warranty will be replacement of the defective product in the U.S., Puerto Rico, or U.S. Virgin Islands. If the Positive Posture product you purchased is discontinued at the time of replacement, a current model of comparable quality and value will be selected.

Except as otherwise provided herein, Positive Posture will not charge purchaser to repair or replace purchaser's mattress or flat foundation if it is deemed defective during the length of this 10 year Limited Warranty. Any transportation costs associated with repairs or replacements are purchaser's responsibility. In no event, however, will the transportation costs exceed Positive Posture's then standard freight charges.

No new warranty is provided with a replacement product. The warranty for the replacement product runs from the date of original purchase of the replaced product.

In connection with the replacement of a product in compliance with the terms of this Limited Warranty, if a purchaser elects to upgrade to a more expensive product, it may do so by paying the difference between the cost of the original product being replaced and the cost of the upgraded product plus the cost of any related additional sleep system pieces not being replaced as part of the warranty exchange. In the event of an upgrade as described in this paragraph, a new warranty will be provided for the upgraded pieces only.

EXCULPATION AND INDEMNIFICATION

Our maximum liability under this Limited Warranty is limited to the cost of repairing or replacing defective Product. We shall not be liable to you for incidental and consequential damages. Some States do not allow the exclusion or limitation of incidental or consequential damages, so the above limitation or exclusion may not apply to you. We shall not be liable for, and you hereby indemnify and hold us and every authorized service provider harmless from, damage, claim, or cause of action, direct or indirect, incidental or consequential, occurring to you, or to the employees or agents of you, or to any other third party, or to the property of any of the foregoing, which may arise as a result of any defect covered by this Limited Warranty or as a result of any service performed under this Limited Warranty. This Limited Warranty gives you specific legal rights, and you may also have other rights, which vary from state to state.

HOW TO MEASURE A DEPRESSION

In the unlikely event of a noticeable depression on your Positive Posture mattress, please put a rigid bar (wood or metal) over your mattress; measure the depression with a ruler. See the illustration below.

